



KESLA



TEHTY SUOMESSA
MADE IN FINLAND

#yourlifetimematch

KESLA C645T heavy duty

Sprung 2-axel chipper,
designed for heavy duty use

YOU SAVE
£10,000

KESLA C645T HEAVY DUTY

At Kesla we listen and respond to the needs of a chipping contractor. We know contractors want high quality wood chip efficiently and effectively, without long downtimes on the machine. We at Kesla have invested heavily in technology to ensure the wood chip is consistently good. The usability of this machine is excellent with low maintenance.

KESLA C645T heavy duty chipper is equipped with tandem axles on leaf springs and designed for heavy duty use. It can also be equipped with hydraulic roller drive with options for pneumatic or hydraulic brakes.

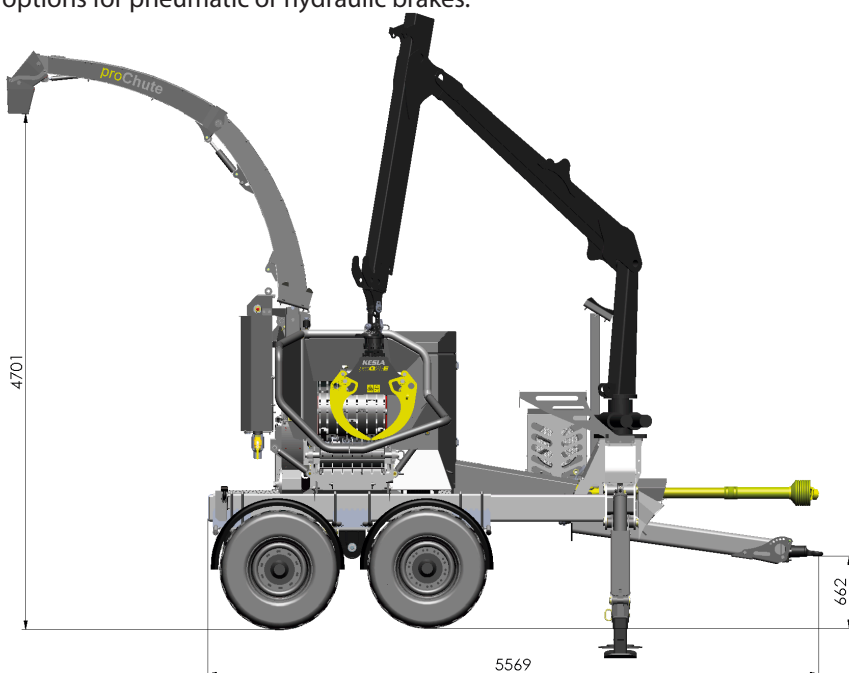

| TECHNICAL DATA | |
|-------------------------------|------------------------------|
| Chip output | ~120 m ³ /h* |
| Fuel consumption | ~ 0,5 l/m ³ * |
| Suggested power requirement | 140-260 kW |
| Intake opening | 630 x 420 mm |
| Drum diameter | 605 mm |
| Knives | 6 |
| Drum rpm | 800-1 000 rpm |
| Electric system | 12 V DC |
| Weight w/o crane | 8 200 kg** |
| Length | 5 570 mm |
| Width | 2 550 mm |
| Maximum height | 4 000 mm |
| Ground clearance | 420 mm |
| Axles | 2 |
| Height of the discharge chute | 4 700 mm |
| Loader options | KESLA 305T, 316T, 600T, 700T |

* Chipping output and fuel consumption are dependent on the chipper adjustments and chipped material.

** The weight is dependent on the accessories chosen.

The benefit is valid for new factory orders made between 15.2.-30.6.2021. The conditions are applicable for KESLA C645SS and KESLA C645T heavy duty -chipper + 316T-700T -loader sets. Prices VAT 0 %. For more information, contact your dealer. Kesla reserves the right for alterations.

CONTACT YOUR DEALER AND TAKE ADVANTAGE OF THE £10,000 BENEFIT !

YOUR DEALER: