

KESLA

TEHTY SUOMESSA
MADE IN FINLAND

Get your lifetime investment match

KESLA C645S

Agile tractor chipper with single axle

YOU SAVE
€10,000

At Kesla we listen and respond to the needs of a chipping contractor. We know contractors want high quality wood chip efficiently and effectively, without long downtimes on the machine. That is why at we at Kesla have invested heavily in technology to ensure the wood chip is consistently of high quality. The usability of the machine is excellent with low maintenance.

Due to its single axle and the 2-cylinder drawbar steering, the Kesla C645S chipper is an agile companion for your tractor.

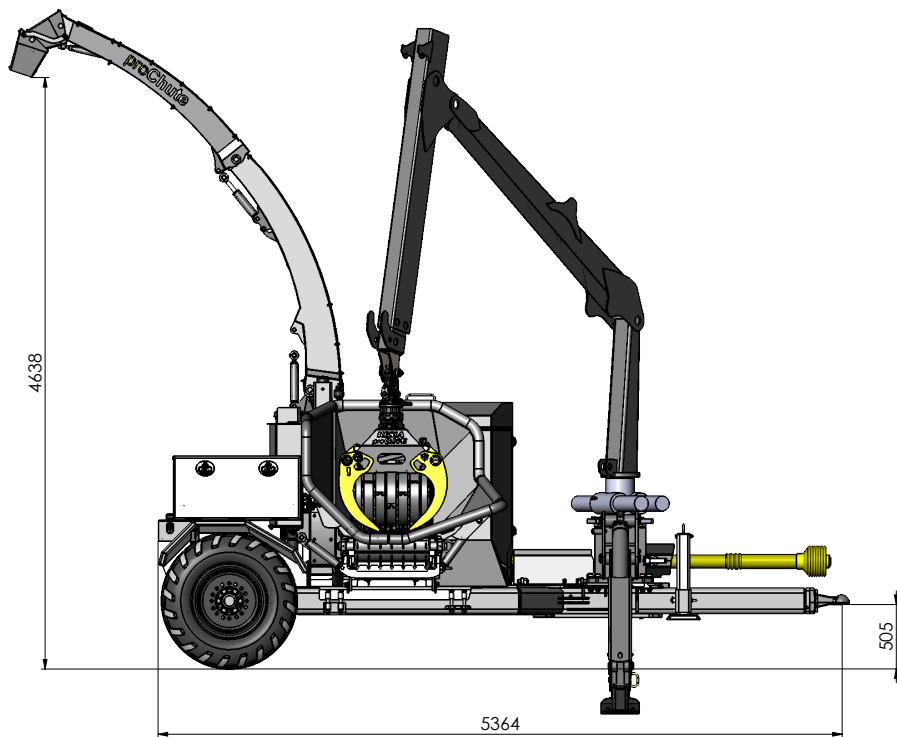

| TECHNICAL DATA | | |
|-------------------------------|--|------------------------------|
| Chip output | | ~120 m ³ /h* |
| Fuel consumption | | ~ 0,5 l/m ³ * |
| Recommended power intake | | 140-260 kW |
| Intake opening | | 630x420 mm |
| Drum diameter | | 605 mm |
| Knives | | 6 |
| Drum rpm | | 800-1000 rpm |
| Electric system | | 12 V DC |
| Weight w/o crane | | 7 800 kg** |
| Length | | 5 370 mm |
| Width | | 2 550 mm |
| Maximum height | | 3640 mm |
| Ground clearance | | 390 mm |
| Axles | | 1 |
| Height of the discharge chute | | 4 640 mm |
| Loader options | | KESLA 305T, 316T, 600T, 700T |

* Chipping output and fuel consumption are dependent on the chipper adjustments and chipped material.

** The weight is dependent on the accessories chosen.

The benefit is valid for new factory orders made between 15.2.-30.6.2021. The conditions are applicable for KESLA C645SS and T heavy duty -chipper + 316T-700T -loader sets. Prices VAT 0 %. For more information, contact your dealer. Kesla reserves the right for alterations.

**CONTACT YOUR DEALER AND
TAKE ADVANTAGE OF THE £10,000 BENEFIT !**

YOUR DEALER: